

Steel Gate Valves—Flanged and Butt-Welding Ends, Bolted and Pressure Seal Bonnets

API STANDARD 600
TENTH EDITION, FEBRUARY 1997

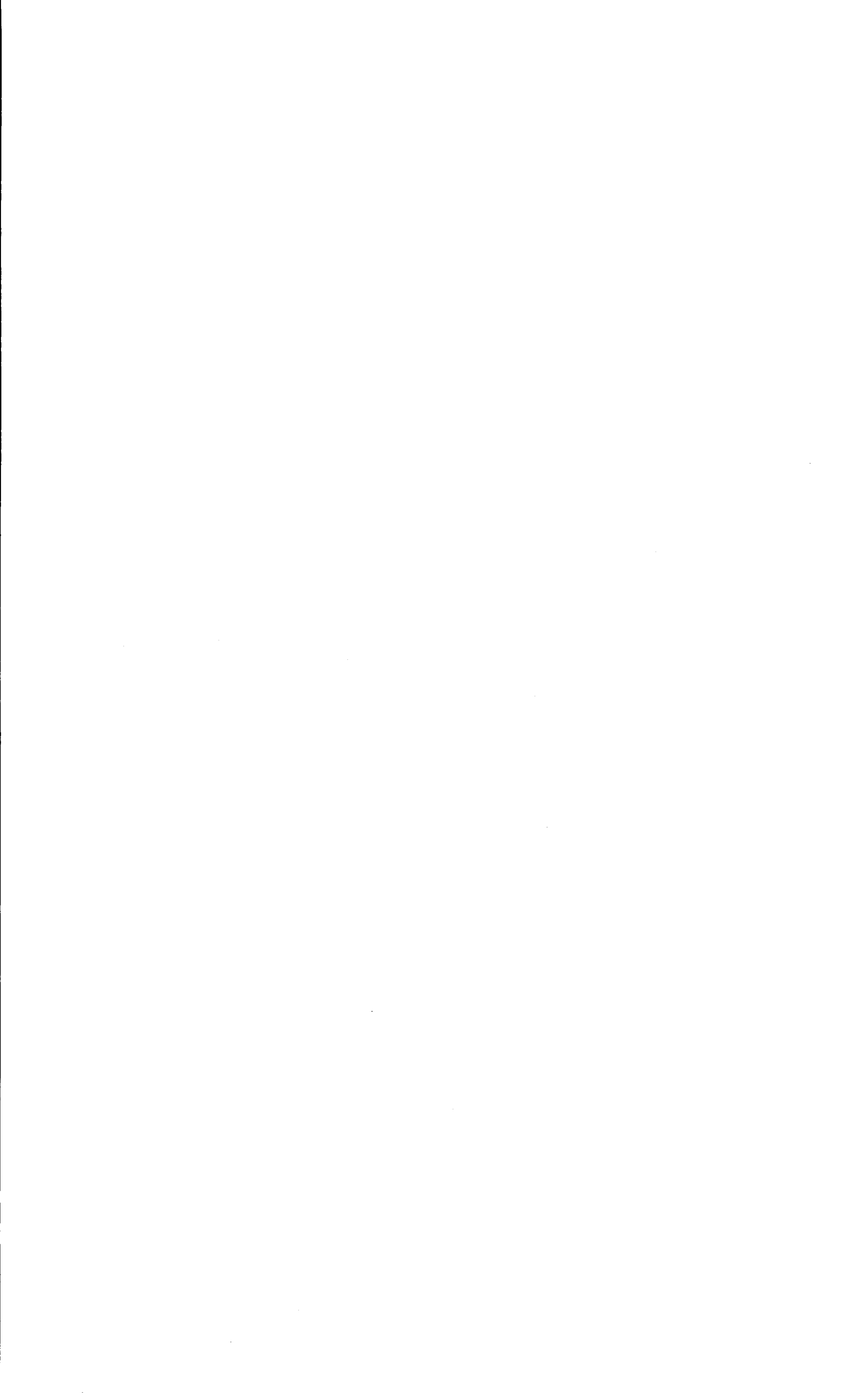



Steel Gate Valves—Flanged and Butt-Welding Ends, Bolted and Pressure Seal Bonnets

Manufacturing, Distribution and Marketing Department

API STANDARD 600
TENTH EDITION, FEBRUARY 1997



SPECIAL NOTES

API publications necessarily address problems of a general nature. With respect to particular circumstances, local, state, and federal laws and regulations should be reviewed.

API is not undertaking to meet the duties of employers, manufacturers, or suppliers to warn and properly train and equip their employees, and others exposed, concerning health and safety risks and precautions, nor undertaking their obligations under local, state, or federal laws.

Information concerning safety and health risks and proper precautions with respect to particular materials and conditions should be obtained from the employer, the manufacturer or supplier of that material, or the material safety data sheet.

Nothing contained in any API publication is to be construed as granting any right, by implication or otherwise, for the manufacture, sale, or use of any method, apparatus, or product covered by letters patent. Neither should anything contained in the publication be construed as insuring anyone against liability for infringement of letters patent.

Generally, API standards are reviewed and revised, reaffirmed, or withdrawn at least every five years. Sometimes a one-time extension of up to two years will be added to this review cycle. This publication will no longer be in effect five years after its publication date as an operative API standard or, where an extension has been granted, upon republication. Status of the publication can be ascertained from the API Authoring Department [telephone (202) 682-8000]. A catalog of API publications and materials is published annually and updated quarterly by API, 1220 L Street, N.W., Washington, D.C. 20005.

This document was produced under API standardization procedures that ensure appropriate notification and participation in the developmental process and is designated as an API standard. Questions concerning the interpretation of the content of this standard or comments and questions concerning the procedures under which this standard was developed should be directed in writing to the director of the Authoring Department (shown on the title page of this document), American Petroleum Institute, 1220 L Street, N.W., Washington, D.C. 20005. Requests for permission to reproduce or translate all or any part of the material published herein should also be addressed to the director.

API standards are published to facilitate the broad availability of proven, sound engineering and operating practices. These standards are not intended to obviate the need for applying sound engineering judgment regarding when and where these standards should be utilized. The formulation and publication of API standards is not intended in any way to inhibit anyone from using any other practices.

Any manufacturer marking equipment or materials in conformance with the marking requirements of an API standard is solely responsible for complying with all the applicable requirements of that standard. API does not represent, warrant, or guarantee that such products do in fact conform to the applicable API standard.

All rights reserved. No part of this work may be reproduced, stored in a retrieval system, or transmitted by any means, electronic, mechanical, photocopying, recording, or otherwise, without prior written permission from the publisher. Contact the Publisher, API Publishing Services, 1220 L Street, N.W., Washington, D.C. 20005.

FOREWORD

This standard is a purchase specification for steel gate valves with flanged or butt-welding ends. This standard is for the convenience of purchasers and manufacturers who order, fabricate, or install steel gate valves.

This standard requires the purchaser to specify certain details and features. Although it is recognized that the purchaser may desire to modify, delete, or amplify sections of this standard, it is strongly recommended that such modifications, deletions, and amplifications be made supplementing this standard, rather than by rewriting or incorporating sections thereof into another complete standard.

API standards are published as an aid to procurement of standardized equipment and materials. These standards are not intended to inhibit purchasers or producers from purchasing or producing products made to specifications other than those of API.

API publications may be used by anyone desiring to do so. Every effort has been made by the Institute to assure the accuracy and reliability of the data contained in them; however, the Institute makes no representation, warranty, or guarantee in connection with this publication and hereby expressly disclaims any liability or responsibility for loss or damage resulting from its use or for the violation of any federal, state, or municipal regulation with which this publication may conflict.

Suggested revisions are invited and should be submitted to the director of the Manufacturing, Distribution and Marketing Department, American Petroleum Institute, 1220 L Street, N.W., Washington, D.C. 20005.

IMPORTANT INFORMATION CONCERNING USE OF ASBESTOS OR ALTERNATIVE MATERIALS

Asbestos is specified or referenced for certain components of the equipment described in some API standards. It has been of extreme usefulness in minimizing fire hazards associated with petroleum processing. It has also been a universal sealing material, compatible with most refining fluid services.

Certain serious adverse health effects are associated with asbestos, among them the serious and often fatal diseases of lung cancer, asbestosis, and mesothelioma (a cancer of the chest and abdominal linings). The degree of exposure to asbestos varies with the product and the work practices involved.

Consult the most recent edition of the Occupational Safety and Health Administration (OSHA), U.S. Department of Labor, Occupational Safety and Health Standard for Asbestos, Tremolite, Anthophyllite, and Actinolite, 29 *Code of Federal Regulations* Section 1910.1001; the U.S. Environmental Protection Agency, National Emission Standard for Asbestos, 40 *Code of Federal Regulations* Sections 61.140 through 61.156; and the U.S. Environmental Protection Agency (EPA) rule on labeling requirements and phased banning of asbestos products (Sections 763.160-179).

There are currently in use and under development a number of substitute materials to replace asbestos in certain applications. Manufacturers and users are encouraged to develop and use effective substitute materials that can meet the specifications for, and operating requirements of, the equipment to which they would apply.

SAFETY AND HEALTH INFORMATION WITH RESPECT TO PARTICULAR PRODUCTS OR MATERIALS CAN BE OBTAINED FROM THE EMPLOYER, THE MANUFACTURER OR SUPPLIER OF THAT PRODUCT OR MATERIAL, OR THE MATERIAL SAFETY DATA SHEET.

CONTENTS

	Page
SECTION 1—GENERAL	1
1.1 Scope	1
1.2 Referenced Publications	1
1.3 Pressure-Temperature Ratings	2
SECTION 2—DESIGN	2
2.1 Body	2
2.2 Bonnet	3
2.3 Gate	6
2.4 Yoke	6
2.5 Handwheel and Handwheel Nut	6
2.6 Stem and Stem Nut	6
2.7 Stuffing Box, Packing, and Lantern Ring	8
2.8 Bolting	8
2.9 Operation	9
2.10 Bypass	9
SECTION 3—MATERIAL	9
3.1 Shell	9
3.2 Body Seat Rings	9
3.3 Bonnet Gasket	9
3.4 Gate	9
3.5 Yoke	9
3.6 Handwheel, Chainwheel, and Nut	9
3.7 Stem Nut	10
3.8 Gland Flange and Gland	10
3.9 Trim	10
3.10 Lantern Ring	10
3.11 Stem Packing	10
3.12 Bolting	10
3.13 Plug	10
3.14 Bypass	10
3.15 Nameplate	10
SECTION 4—EXAMINATION, INSPECTION, AND TESTING	12
4.1 Inspection	12
4.2 Pressure Tests	12
4.3 Repair of Defects	12
SECTION 5—MARKING	12
SECTION 6—SHIPMENT	12
6.1 Coatings	12
6.2 Openings	12
6.3 Gate Position	12
6.4 Stem Packing	12
6.5 Packaging	12
APPENDIX A—Requirements For Pressure Seal Gate Valves	13

CONTENTS

	Page
Figures	
1—Typical Bolted Bonnet Gate Valve Nomenclature	2
2—Types of Gates	6
3—Wear Travel of Wedge Gate	7
A-1—Pressure Seal Bonnet Gate Valve Nomenclature	15
Tables	
1A—Minimum Thickness of the Shell Wall and Minimum Diameter of the Stem, in Inches	4
1B—Minimum Thickness of the Shell Wall and Minimum Diameter of the Stem, in Millimeters	5
1C—Permitted Undertolerance	7
2—Stuffing Box Bore and Packing Width	8
3—Nominal Seating Surface, Stem and Backseat Bushing or Weld-Deposit Materials and Hardness	11
4—Trim Numbers and Alternative Trim Numbers	11
A-6A—Style A Minimum Stem Diameter (Inches)	14
A-6B—Style A Minimum Stem Diameter (Millimeters)	14

NOTES TO PURCHASER

1. If the purchaser needs a steel gate valve that deviates from the specifications of this standard, the deviations shall be specifically stated in the purchase order.
2. If no exceptions are to be taken to this standard, the purchase order just needs to refer to API Standard 600 and to specify the items in the following list that are marked with an asterisk (*). The items listed below without an asterisk are options that may also be specified.
 - *a. Valve size (see 1.1.1 and A.1.1.1).
 - *b. Pressure class (see 1.1.2 and A.1.1.2). Standard or special class (see A.1.3.1).
 - *c. Bonnet style (see 1.1).
 - *d. Pressure seal bonnet valve style (see A.1.1.3).
 - *e. Flanged ends, including facing; or welding ends, including bore (see 2.1).
 - *f. Welded end flanges, if desired (see Note 3 and 2.1).
 - g. Auxiliary connections and openings (see 2.1.8, 2.1.10, and 2.2.7).
 - *h. Wedge gate or double-disc gate; also type of wedge, if required (see 2.3).
 - i. Lantern ring, if required (see 2.7.4).
 - j. Chainwheel and chain, if required (see 2.9.2).
 - k. Gear operation, if required, including type and arrangement, and the design maximum pressure differential across the valve (see 2.9.2).
 - l. Power operation, if required, including type of power and power unit, and the design maximum pressure differential across the valve (see 2.9.4).
 - m. Bypass, if required. Specify either flanged or welded bonnet bypass valve (see 2.10).
 - *n. Material of the valve shell (see 3.1).
 - o. Bonnet gasket and/or bonnet flange facing, if alloy material is specified for valve body or valve service temperature exceeds 1000°F (538°C) (see 2.2.2 and 3.3).
 - *p. Trim number, nominal trim material, and any required exceptions to manufacturer's permissible options (see Table 3 and 3.9).
 - q. Special stem packing required. [specify packing design if temperature is above 1000°F (538 °C)] (see 3.11).
 - r. Bonnet bolting material for bolt metal temperatures below -20°F (-29°C) or above 850°F (454°C) or for increased resistance to corrosive environments (see 3.12).
 - s. Inspection by the purchaser, if required (see 4.1 and Note 4).
 - t. High-pressure closure test, if required (see 4.2 and Note 4).
 - u. Export packaging, if required (see 6.5).
 - v. Orientation of installed valve.
 - w. Handwheels (see 3.6.1).
3. If welded end flanges are specified, the purchaser shall ensure that adequate quality control of the welds will be performed by the manufacturer. The purchaser may have to specify supplementary requirements for the welds, particularly for the more severe services (for example, special heat treatment and supplementary nondestructive examination of the welds).
4. Refer to API Standard 598 for additional items that may have to be specified, such as the extent of inspection, the inspector's address, and the optional high-pressure closure test.



Steel Gate Valves—Flanged and Butt-Welding Ends, Bolted and Pressure Seal Bonnets

SECTION 1—GENERAL

1.1 Scope

1.1.1 This standard covers steel gate valves with flanged or butt-welding ends in sizes NPS 1 through NPS 24. These sizes correspond to nominal pipe sizes in ASME B36.10M.

1.1.2 This standard covers valves in Classes 150 through 2500 as specified in ASME B16.34.

1.1.3 This standard covers requirements for a heavy-duty style of bolted bonnet gate valves for petroleum refinery and related applications where corrosion, erosion, and other service conditions indicate a need for full port openings, heavy body wall sections, and large stem diameters. Covered are requirements for outside screw-and-yoke (OS&Y) valves with rising stems, nonrising handwheels, and various types of gate configurations. In addition, Appendix A of this standard covers requirements specifically for pressure seal bonnet gate valves for both a heavy-duty style and a general purpose style for applications where less arduous corrosion and erosion service conditions are confronted or materials are selected so as to ameliorate these conditions.

1.1.4 Figure 1 illustrates a bolted bonnet gate valve for the purpose of establishing standard nomenclature for valve parts.

1.1.5 The dimensions in customary units are standard; metric (SI) units are included for reference.

1.2 Referenced Publications

The most recent edition or revision of the following standards, codes, or specifications shall, to the extent specified, form a part of this standard:

API

- Std 598 *Valve Inspection and Testing*
- Std 602 *Compact Steel Gate Valves—Flanged, Threaded, Welding, and Extended Body Ends*

ASME¹

- B1.1 *Unified Inch Screw Threads (UN and UNR Thread Form)*
- B1.5 *Acme Screw Threads*
- B1.8 *Stub Acme Screw Threads*
- B1.12 *Screw Threads—Class 5 Interference-Fit Thread*
- B16.5 *Pipe Flanges and Flanged Fittings*

¹ American Society of Mechanical Engineers, 345 East 47th Street, New York, New York 10017.

- B16.10 *Face-to-Face and End-to-End Dimensions of Valves*
- B16.11 *Forged Steel Fittings, Socket Welding and Threaded*
- B16.25 *Butt-welding Ends*
- B16.34 *Valves—Flanged, Threaded and Welding End*
- B18.2.2 *Square and Hex Nuts (Inch Series)*
- B31.3 *Chemical Plant and Petroleum Refinery Piping*
- B36.10M *Welded and Seamless Wrought Steel Pipe*

ASTM²

- A 182 *Specification for Forged or Rolled Alloy-Steel Pipe Flanges, Forged Fittings, and Valves and Parts for High-Temperature Service*
- A 193 *Specification for Alloy-Steel and Stainless Steel Bolting Materials for High-Temperature Service*
- A 194 *Specification for Carbon and Alloy Steel Nuts for Bolts for High-Pressure and High-Temperature Service*
- A 217 *Specification for Steel Castings, Martensitic Stainless Steel and Alloy, for Pressure-Containing Parts Suitable for High Temperature Service*
- A 276 *Specification for Stainless and Heat-Resisting Steel Bars and Shapes*
- A 307 *Specification for Carbon Steel Bolts and Studs, 60,000 psi Tensile*
- A 351 *Specification for Steel Castings, Austenitic, for High-Temperature Service*
- A 439 *Specification for Austenitic Ductile Iron Castings*
- B 473 *Specification for UNS No. 8020, UNS No. 8024, UNS No. 8026 Nickel Bar and Wire*
- E 10 *Test Method for Brinell Hardness of Metallic Materials*

AWS³

- A5.9 *Specification for Corrosion-Resisting Chromium and Chromium-Nickel Steel Bare and Composite Metal Cored and Stranded Welding Electrodes and Welding Rods*
- A5.13 *Specification for Solid Surfacing Welding Rods and Electrodes*

² American Society for Testing and Materials, 100 Bar Harbor Drive, West Conshohocken, Pennsylvania 19428.

³ American Welding Society, Inc., 550 N.W. LeJeune Road, Miami, Florida 33125.

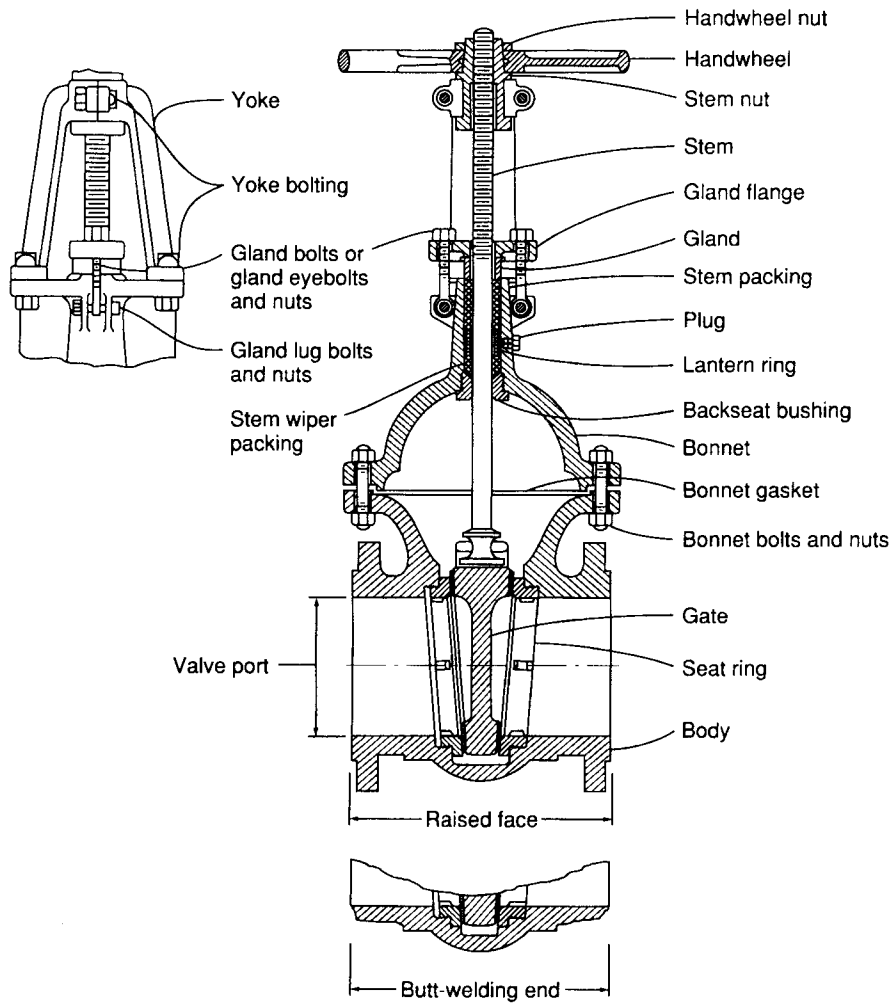

Figure 1—Typical Bolted Bonnet Gate Valve Nomenclature

1.3 Pressure-Temperature Ratings

1.3.1 Pressure-temperature ratings for steel gate valves covered by this standard shall be those listed in ASME B16.34 for Standard Class valves. Each pressure rating is the maximum allowable sustained nonshock pressure at the corresponding tabulated temperature.

1.3.2 The design metal temperature for determining a required pressure rating (maximum allowable pressure at design temperature) shall be selected by the purchaser and is subject to the requirements of any applicable code.

SECTION 2—DESIGN

2.1 Body

2.1.1 The thickness of the body wall of the steel gate valve shall conform to the requirements of Tables 1A or 1B.

2.1.2 The face-to-face dimensions of raised-face and ring-joint flanged-end valves and end-to-end dimensions of butt-

welding-end valves shall conform to the requirements of ASME B16.10. Unless there is an agreement between the purchaser and the manufacturer, short pattern is not permitted for bolted bonnet valves.

2.1.3 End and bonnet flanges shall be cast or forged integrally with the body; however, if specified in the purchase

order, flanges may be attached by welding. Flanges that are attached by welding shall be of the forged butt-welding-end type. The welds and the qualifications for the welding procedure and the welder or welding operator shall conform to the requirements of ASME B31.3.

2.1.4 The dimensions of the end flanges shall be as specified in ASME B16.5 for the type of facing specified in the purchase order.

2.1.5 The facing finish of the end flanges shall be in accordance with the specifications of ASME B16.5. When a more (or less) restrictive facing finish is required, it shall be specified in the purchase order.

2.1.6 Butt-welding ends shall conform to the requirements of ASME B16.25 for the bore specified for use without backing rings. Conversion of a flanged-end valve to a butt-welding-end valve is not permitted except by agreement between the purchaser and manufacturer.

2.1.7 The nominal inside diameter of the seat opening shall not be less than that specified in Annex A of ASME B16.34 for the nominal pipe size and pressure class.

2.1.8 Auxiliary connections to the body, such as drains, shall be furnished only if specified in the purchase order. The design and construction of the joint and the piping of auxiliary connections shall conform to the requirements of ASME B31.3. When required for a valve NPS 2 or larger, auxiliary connections shall be sized and located as specified in ASME B16.34. The size and location of auxiliary connections shall be indicated in the purchase order.

2.1.9 Separate seat rings shall be furnished in the body except as follows:

- a. Austenitic stainless steel valves may have seats that are integral with the body.
- b. If either an austenitic stainless steel or hardfaced body seat material is furnished, the seat material may be weld deposited directly on the valve body.

Separate seat rings may be shoulder seated or bottom seated. They may be threaded, rolled, pressed, or welded in. Threaded seat rings shall be provided with lugs or slots to facilitate removal. A light lubricant, not heavier than kerosene, may be used to facilitate assembly of threaded, rolled, or pressed seat rings, but the use of a sealing compound or grease is prohibited. The seating surfaces of the seat rings shall have a chamfer or radius at the outside and inside diameters. Rolled and pressed-in seat rings shall be limited to use in NPS 2 or smaller valves.

2.1.10 Tapped test openings are permitted only if specified in the purchase order.

2.2 Bonnet

2.2.1 The minimum thickness of the bonnet wall, except for the bonnet neck above the backseat, shall conform to the requirements of Tables 1A or 1B. Above the backseat, the bonnet neck shall conform to the design requirements for valve body necks as specified in ASME B16.34.

2.2.2 The body-to-bonnet joint shall be flanged with a raised-face joint, male-and-female joint, tongue-and-groove joint, or ring joint; however, on a Class 150 valve, the joint may be flat face.

2.2.3 Bonnet flanges shall be circular, except on a Class 150 valve and on valves NPS 2½ or smaller in all ratings. Bonnet flanges shall be spotfaced or backfaced in accordance with the requirements of ASME B16.5 for end flanges. Bonnet flanges shall conform to the requirements of 2.1.3.

2.2.4 The bonnet joint shall have at least four through bolts of the following minimum sizes:

Valv Size (NPS)	Bolt Size, Minimum (inches, nominal)
1-2½	¾
3-8	½
≥10	¾

The total cross-sectional area of the bolts shall be in accordance with the requirements of ASME B16.34.

2.2.5 A machined conical or spherical backseat shall be provided in the bonnet. The backseat shall contact a corresponding seating surface on the valve stem. The bonnet backseat shall be in a bushing at the stem hole, except that for a valve with either austenitic stainless steel or hardfaced trim, the seating surface may be a weld deposit. On an austenitic stainless steel valve, the backseat may be either an integral surface or a weld-deposited hardfacing. Weld-deposited backseat facings shall have a minimum finished thickness of 0.06 inch (1.6 millimeters).

2.2.6 The stem hole in the backseat shall be designed with proper clearance to guide the stem and, when the backseat supports the packing, to prevent extrusion of the packing. Weld-deposited facings shall have a minimum finished thickness of 0.06 inch (1.6 millimeters).

2.2.7 Tapped test openings are permitted only if specified in the purchase order.

2.2.8 The means to secure the gland eyebolts to the bonnet shall not include a stud-weld or fillet-weld attachment, nor slotted brackets.

Table 1A—Minimum Thickness of the Shell Wall and Minimum Diameter of the Stem, in Inches

Valve Size NPS	Class													
	150		300		400		600		900		1500		2500	
	Shell Wall Thickness	Stem Diameter	Shell Wall Thickness	Stem Diameter	Shell Wall Thickness	Stem Diameter	Shell Wall Thickness	Stem Diameter	Shell Wall Thickness	Stem Diameter	Shell Wall Thickness	Stem Diameter	Shell Wall Thickness	Stem Diameter
1	0.25	3/8	0.25	3/8	a	a	0.31	5/8	b	b	0.50	3/4	0.59	3/4
1 1/4	0.25	3/8	0.25	3/8	a	a	0.34	5/8	b	b	0.56	3/4	0.69	3/4
1 1/2	0.25	1/2	0.31	3/4	a	a	0.37	3/4	b	b	0.59	3/4	0.75	3/4
2	0.34	3/4	0.38	3/4	a	a	0.44	3/4	b	b	0.75	1	0.88	1
2 1/2	0.38	3/4	0.44	3/4	a	a	0.47	7/8	b	b	0.88	1 1/4	1.00	1 1/4
3	0.41	3/4	0.47	7/8	a	a	0.50	1	0.75	1 1/4	0.94	1 1/4	1.19	1 1/4
4	0.44	1	0.50	1	0.50	1 1/4	0.63	1 1/4	0.84	1 1/4	1.13	1 1/4	1.41	1 1/4
6	0.47	1 1/4	0.63	1 1/4	0.66	1 1/4	0.75	1 1/2	1.03	1 1/4	1.50	1 1/4	1.91	1 1/4
8	0.50	1 1/4	0.69	1 1/4	0.75	1 1/2	1.00	1 3/4	1.25	1 1/4	1.88	2 1/4	2.44	2 1/4
10	0.56	1 1/4	0.75	1 1/2	0.84	1 1/4	1.13	1 3/4	1.44	2 1/4	2.25	2 1/2	2.66	2 1/4
12	0.63	1 1/2	0.81	1 3/4	0.94	1 1/4	1.25	2	1.66	2 1/4	2.63	2 1/4	3.41	3 1/4
14	0.66	1 1/4	0.88	1 1/4	1.06	1 1/4	1.38	2 1/4	1.81	2 1/4	2.75	3	—	—
16	0.69	1 1/4	0.94	1 1/4	1.13	2	1.50	2 1/4	2.06	2 1/2	3.13	3	—	—
18	0.72	1 1/4	1.00	2	1.19	2 1/4	1.63	2 1/2	2.25	3	3.50	—	—	—
20	0.75	2	1.06	2 1/4	1.31	2 1/2	1.75	2 3/4	2.50	—	3.88	—	—	—
24	0.81	2 1/4	1.19	2 1/2	1.44	2 1/4	2.00	3	2.88	—	4.50	—	—	—

Note: The shell comprises the body and the bonnet. The diameters listed are for the stem in the packing area and for the major diameter of the operating threads. An under-tolerance is permitted in accordance with Table 1C. For dimensions in millimeters, see Table 1B.

^aUse Class 600 valves in these sizes.

^bUse Class 1500 valves in these sizes.

Table 1B—Minimum Thickness of the Shell Wall and Minimum Diameter of the Stem, in Millimeters

Valve Size NPS	Class													
	150		300		400		600		900		1500		2500	
	Shell Thickness	Stem Diameter	Shell Thickness	Stem Diameter	Shell Thickness	Stem Diameter	Shell Thickness	Stem Diameter	Shell Thickness	Stem Diameter	Shell Thickness	Stem Diameter	Shell Thickness	Stem Diameter
1	6.4	15.9	6.4	15.9	a	a	7.9	15.9	b	b	12.7	19.1	15.0	19.1
1¼	6.4	15.9	6.4	15.9	a	a	8.6	15.9	b	b	14.2	19.1	17.5	19.1
1½	6.4	17.5	7.9	19.1	a	a	9.4	19.1	b	b	15.0	22.2	19.1	22.2
2	8.6	19.1	9.7	19.1	a	a	11.2	19.1	b	b	19.1	25.4	22.4	25.4
2½	9.7	19.1	11.2	19.1	a	a	11.9	22.2	b	b	22.4	28.6	25.4	28.6
3	10.4	22.2	11.9	22.2	a	a	12.7	25.4	19.1	28.6	23.9	31.8	30.2	31.8
4	11.2	25.4	12.7	25.4	12.7	28.6	16.0	28.6	21.3	31.8	28.7	34.9	35.8	34.9
6	11.9	28.6	16.0	31.8	16.8	34.9	19.1	38.1	26.2	41.3	38.1	44.5	48.5	47.6
8	12.7	31.8	17.5	34.9	19.1	38.1	25.4	41.3	38.1	47.6	47.8	54.0	62.0	60.3
10	14.2	34.9	19.1	38.1	21.3	44.5	28.7	46.7	36.6	54.0	57.2	63.5	67.6	73.0
12	16.0	38.1	20.6	41.3	23.9	47.6	31.8	50.8	42.2	57.2	66.8	69.9	86.6	82.6
14	16.8	41.3	22.4	44.5	26.9	47.6	35.1	57.2	46.0	60.3	69.9	76.2	—	—
16	17.5	44.5	23.9	47.6	28.7	50.8	38.1	60.3	52.3	63.5	79.5	76.2	—	—
18	18.3	47.6	25.4	50.8	30.2	57.2	41.4	63.5	57.2	76.2	88.9	—	—	—
20	19.1	50.8	26.9	54.0	33.3	63.5	44.5	69.9	63.5	—	98.6	—	—	—
24	20.6	57.2	30.2	63.5	36.6	69.9	50.8	76.2	73.2	—	114.3	—	—	—

Note: The shell comprises the body and the bonnet. The diameters listed are for the stem in the packing area and for the major diameter of the operating threads. An undertolerance is permitted in accordance with Table 1C. For dimensions in inches, see Table 1A.

^aUse Class 600 valves in these sizes.

^bUse Class 1500 valves in these sizes.

2.3 Gate

2.3.1 The types of gates are illustrated in Figure 2 and are classified as follows:

- Wedge gate, including one-piece solid wedge, one-piece flexible wedge, and two-piece split wedge.
- Double-disc gate.

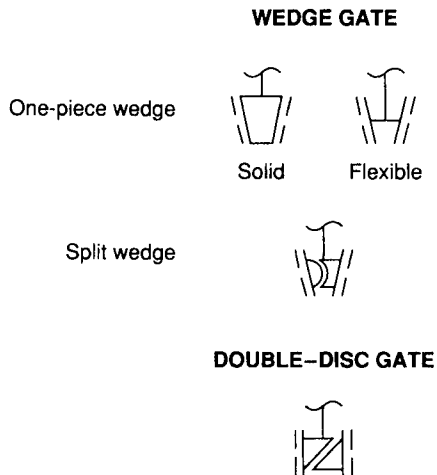

Figure 2—Types of Gates

2.3.2 Unless otherwise specified in the purchase order, the gate shall be a wedge gate. Except for a double-disc gate, the fully open gate shall completely clear the valve seat openings.

2.3.3 If a wedge gate is used, a one-piece wedge shall be furnished unless a split wedge is specified in the purchase order.

2.3.4 A one-piece wedge gate may be fabricated by welding. It may be either a solid wedge with a trapezoidal or I-shaped cross section or a flexible wedge with a tapered cross section. Unless the purchase order specifies a solid wedge or a flexible wedge, either type of wedge may be furnished.

2.3.5 A split-wedge gate is a two-piece gate. The positioning of the two parts of the gate is up to the manufacturer. The valve shall be designed so that the parts cannot become separated, regardless of the gate's position or the valve's orientation.

2.3.6 A double-disc gate valve shall have parallel seats and an internal spreading device (for example, a wedging device or spring) that forces the two discs firmly against the body seats when the gate is in the closed position.

2.3.7 The gate and shell shall have guide surfaces to minimize wear of the seats during operation of the valve and to ensure the alignment of the disc and stem in all orientations. The possible loss of metal due to corrosion, erosion, abrasive

wear, or a combination of these factors shall be considered in the design of both the gate and the shell guide surfaces.

2.3.8 Gate seating surfaces shall be integral or shall consist of deposited weld metal. Unless a hardface trim is specified in the purchase order, the seats are not required to be weld hardfaced. Facings shall be welded to provide a minimum finished thickness of 0.06 inch (1.6 millimeter).

2.3.9 For a wedge gate valve, the seating design shall provide an adequate seating width, both before and after wear of the seating surfaces. The width of the body and gate seats shall be proportioned so that, by seating the new gate high on the body seats, the gate seats will still completely contact the full effective seating width of the body seats after the gate's closed position has traveled down (because of seat wear) by a distance (wear travel) not less than the following:

Valve Size (NPS)	Wear Travel, Minimum	
	(inches)	(millimeters)
1–2	0.09	2.3
2½	0.13	3.3
8–12	0.25	6.4
14–18	0.38	9.7
20–24	0.50	12.7

Wear travel of a wedge gate is illustrated in Figure 3.

2.4 Yoke

The yoke may be integral with or separate from the bonnet. In both cases, the design shall be such that the stem nut can be replaced with the stem secured without affecting the pressure retaining capability of the bonnet assembly. However, replacement under pressure is not recommended. In both cases, the yoke-to-stem nut bearing surfaces shall be machined and in the case of a separate yoke, the yoke-to-bonnet connecting faces shall also be machined. The yoke-to-stem nut bearing surfaces shall be provided with a lubrication fitting.

2.5 Handwheel and Handwheel Nut

2.5.1 The handwheel for a direct handwheel-operated valve shall have a spoke-and-rim design with no more than six spokes.

2.5.2 Unless the size of the wheel makes it impracticable, the handwheel shall be marked with the word "open" and an arrow pointing in the direction in which the valve opens.

2.5.3 The handwheel shall be fixed to the stem nut by a threaded handwheel nut.

2.6 Stem and Stem Nut

2.6.1 The minimum stem diameter shall be in accordance with Tables 1A or 1B. To allow the use of standard-diameter round bars, an undertolerance is permitted in accordance with Table 1C.

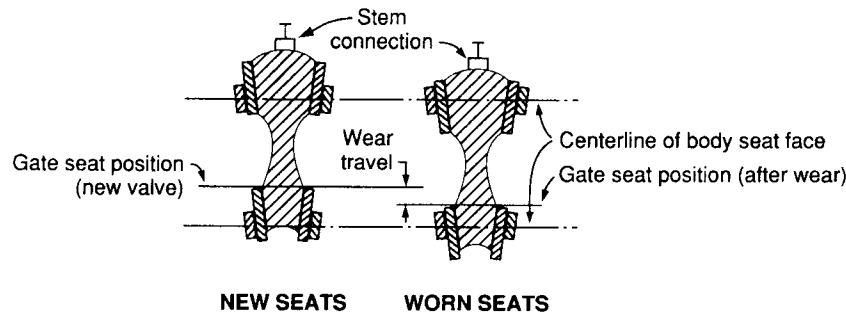

Figure 3—Wear Travel of Wedge Gate

2.6.2 The stem connection to a wedge gate shall be a T-head that is integral (without welding) with the stem. The stem connection to a double-disc gate may be threaded. The stem connection shall prevent the stem from turning or disengaging from the gate while the valve is in service. For an OS&Y valve, the stem train (stem, gate, stem nut, bandwheel, and handwheel nut) shall be designed to fail outside the pressure boundary in the event of a locked gate. The strength of the stem (in tension) outside the pressure boundary shall not be less than the calculated (theoretical) failure load based on the thread root area and the minimum ultimate tensile strength of the stem material. The strength (in tension) of the stem-to-gate connection and of all parts of the stem within the pressure boundary shall be greater than the strength at the root of the threads.

2.6.3 The stem shall have an integral conical or spherical backseat surface to seat against the bonnet backseat when the gate is in the fully open position.

2.6.4 The stem shall be operated by a rotating stem nut mounted at the top of the yoke. The stem nut shall have a hexagonal shank, a round shank with a keyway, or another drive of equivalent strength and durability for attachment to the handwheel. The stem nut arrangement shall be designed to permit removal of the handwheel without allowing the stem and gate to drop into the closed position if the handwheel is removed when the valve is in the open position. When a threaded bushing is used to retain the stem nut, the bushing shall be retained by a weld or other suitable means to ensure that there is no movement during operation of the valve. Metal peening (staking) is not permitted.

2.6.5 The threads of the stem and stem nut shall be Acme type conforming to ASME B1.5 or stub threads conforming to ASME B1.8 (minor modifications are permitted for either thread). The Acme thread major diameter may be less by a maximum of $\frac{1}{16}$ inch (1.6 millimeters) than the diameter of the stem shown in Tables 1A and 1B. On direct handwheel-operated valves, these threads shall be left-handed threads. (Clockwise rotation of the handwheel shall close the valve.)

2.6.6 Stem threads shall project outside the stem nut on a new closed valve by a distance that is at least equal to the required wear travel distance. The maximum projection of the stem thread shall be five times the wear travel distance for valves less than or equal to NPS 6 and three times the wear travel distance for valves greater than NPS 6.

2.6.7 All contact surfaces between the stem nut and the yoke shall be flat and parallel. Ball or roller bearings shall be furnished for pressure classes and valve sizes as follows:

- a. Class 400, NPS 10 or larger.
- b. Class 600, 900, 1500, or 2500, NPS 6 or larger.

2.6.8 The stem shall have a surface finish R_a of 32 micro-inches (0.80 micrometer) or smoother in the area in contact with the packing.

Table 1C—Permitted Undertolerance

Minimum		Minimum	
Diameter	Undertolerance	Diameter	Undertolerance
$\leq \frac{3}{8}$	0.012	≤ 15.9	0.31
$> \frac{3}{8}$ to $\frac{1}{2}$	0.013	> 15.0 to 22.2	0.33
$> \frac{1}{2}$ to 1	0.014	> 22.2 to 25.4	0.36
> 1 to $1\frac{1}{8}$	0.015	> 25.4 to 28.6	0.38
$> 1\frac{1}{8}$ to $1\frac{1}{4}$	0.016	> 28.6 to 31.8	0.41
$> 1\frac{1}{4}$ to $1\frac{3}{8}$	0.017	> 31.8 to 34.9	0.43
$> 1\frac{3}{8}$ to $1\frac{1}{2}$	0.019	> 34.9 to 38.1	0.48
$> 1\frac{1}{2}$ to $1\frac{3}{4}$	0.021	> 38.1 to 41.3	0.53
$> 1\frac{3}{4}$ to 2	0.026	> 41.3 to 50.8	0.66
> 2 to $3\frac{1}{4}$	0.030	> 50.8 to 82.6	0.76

Note: The diameters listed in Tables 1A and 1B are for the stem in the packing area and for the major diameter of the operating threads. An undertolerance is permitted in accordance with this table.

2.7 Stuffing Box, Packing, and Lantern Ring

2.7.1 The stuffing box dimensions shall accommodate the packing specified in Table 2. The stuffing box depth (for square packing width shown in Table 2) shall accommodate a minimum of five uncompressed rings of packing, except as specified in 2.7.4. The stuffing box shall have a finish R_a of 125 microinches (3.2 micrometers) or smoother, unless otherwise specified in the purchase order.

2.7.2 The packing gland shall be flanged, with holes (not slots) for two gland bolts. The gland shall be a two-piece, self-aligning design, consisting of a gland proper and a separate gland flange. The gland proper shall have a shoulder on its outer end to prevent complete entry of the gland into the stuffing box.

2.7.3 The packing may be square or rectangular.

2.7.4 A lantern ring shall be furnished only if specified in the purchase order. The lantern ring shall have two holes spaced 180 degrees apart on each end for its removal. These holes shall be either through holes for use with a hook or threaded holes of the $\frac{1}{2}$ -coarse-thread series (No. 5-40 UNC),

as specified in ASME B1.1. If a lantern ring is furnished, the stuffing box shall be tapped opposite the center of the installed lantern ring and shall be fitted with a threaded solid round- or hex-head plug greater than or equal to NPS $\frac{1}{4}$. The plug shall be in accordance with the requirements of ASME B16.11. The stuffing box shall have a boss as specified in ASME B16.34. When a lantern ring is furnished, the stuffing box depth shall be at least equivalent to that of a minimum of three uncompressed rings of packing above the lantern ring and three uncompressed rings of packing below the lantern ring, plus the length of the lantern ring.

2.8 Bolting

2.8.1 Bonnet flange bolts shall be continuously threaded stud bolts with heavy, semifinished hexagon nuts conforming to the requirements of ASME B18.2.2.

2.8.2 Yoke bolting shall be continuously threaded stud bolts or headed bolts, with hexagon nuts.

2.8.3 Gland bolting shall be headed bolts, hinged eyebolts or stud bolts, with hexagon nuts.

Table 2—Stuffing Box Bore and Packing Width

Nominal Stem Diameter		Nominal Packing Width		Nominal Stuffing Box Bore	
Inches	Millimeters	Inches	Millimeters	Inches	Millimeters
$\frac{1}{4}$	15.9	$\frac{1}{4}$	6.4	$1\frac{1}{32}$	29.4
$\frac{3}{8}$	19.1	$\frac{1}{4}$	6.4	$1\frac{1}{32}$	32.5
$\frac{7}{8}$	22.2	$\frac{1}{4}$	6.4	$1\frac{1}{32}$	35.7
1	25.4	$\frac{1}{4}$	6.4	$1\frac{1}{32}$	38.9
$1\frac{1}{8}$	28.6	$\frac{5}{16}$	7.9	$1\frac{15}{32}$	45.2
$1\frac{1}{4}$	31.8	$\frac{5}{16}$	7.9	$1\frac{29}{32}$	48.4
$1\frac{3}{8}$	34.9	$\frac{5}{16}$	7.9	$2\frac{1}{32}$	51.6
$1\frac{1}{2}$	38.1	$\frac{3}{8}$	9.5	$2\frac{1}{32}$	57.9
$1\frac{5}{8}$	41.3	$\frac{3}{8}$	9.5	$2\frac{11}{32}$	61.1
$1\frac{3}{4}$	44.5	$\frac{3}{8}$	9.5	$2\frac{17}{32}$	64.3
$1\frac{7}{8}$	47.6	$\frac{3}{8}$	9.5	$2\frac{21}{32}$	67.5
2	50.8	$\frac{7}{16}$	11.1	$2\frac{25}{32}$	73.8
$2\frac{1}{8}$	54.0	$\frac{7}{16}$	11.1	$3\frac{1}{32}$	77.0
$2\frac{1}{4}$	57.2	$\frac{1}{2}$	12.7	$3\frac{5}{32}$	83.3
$2\frac{3}{8}$	60.3	$\frac{1}{2}$	12.7	$3\frac{9}{32}$	86.5
$2\frac{1}{2}$	63.5	$\frac{1}{2}$	12.7	$3\frac{13}{32}$	89.7
$2\frac{3}{4}$	69.9	$\frac{1}{2}$	12.7	$3\frac{27}{32}$	96.0
$2\frac{7}{8}$	73.0	$\frac{1}{2}$	12.7	$3\frac{31}{32}$	99.2
3	76.2	$\frac{9}{16}$	14.3	$4\frac{3}{32}$	105.6
$3\frac{1}{4}$	82.6	$\frac{9}{16}$	14.3	$4\frac{7}{32}$	111.9

Note: For stem diameters not listed, the packing width and stuffing box bore shall be in proportion to those shown.

2.8.4 Bolting that is 1 inch in diameter or smaller shall have coarse (UNC) threads. Bolting that is larger than 1 inch shall be of the 8-thread series (8 UN). Bolt threads shall be Class 2A, and nut threads shall be Class 2B, conforming to the requirements of ASME B1.1; however, studs used for gland bolting shall be secured with a Class 5 interference fit, conforming to the requirements of ASME B1.12.

2.9 Operation

2.9.1 Unless otherwise specified in the purchase order, the valve shall be direct handwheel operated.

2.9.2 If chainwheel operation is required, the type of chain and chainwheel shall be specified in the purchase order.

2.9.3 If gear operation is required, the purchase order shall specify the type of gears and their arrangement, the maximum differential pressure across the valve, and the maximum force (rim-pull) to operate the valve. (The last shall be the force exerted on the outer circumference of the handwheel.)

2.9.4 If power operation is required, the type of power and the power unit, as well as the design maximum pressure

differential across the valve, shall be specified in the purchase order.

2.10 Bypass

2.10.1 A bypass shall not be furnished unless it is specified in the purchase order.

2.10.2 Unless otherwise specified in the purchase order, any bypass that is furnished shall be of the valve external type and of a size that is specified in ASME B16.34. The bypass shall be located on the side of the valve that connects either the A–B or the E–F locations shown in ASME B16.34. The stem of the bypass valve shall have the same general orientation as the stem of the primary valve.

2.10.3 The bypass valve shall be of the globe type, OS&Y, and shall have a rising stem with a flanged or welded bonnet, as specified in the purchase order. The bypass valve shall be of a class that is at least equal to that of the primary valve and shall conform to the applicable requirements of API Standard 602.

2.10.4 Bypass piping shall conform to the requirements of 2.1.8.

SECTION 3—MATERIAL

3.1 Shell

The body and bonnet shall be made of the material specified in the purchase order, using a material listed in ASME B16.34.

3.2 Body Seat Rings

If an overlay weld deposit is used for the seating surface of the body seat ring, the corrosion resistance of the seat ring base material shall be at least equal to that of the shell material.

3.3 Bonnet Gasket

3.3.1 The bonnet flange gasket shall be (a) corrugated or flat solid metal; (b) corrugated or flat filled metal jacketed; (c) a metal ring joint; (d) for use only in Class 150, a flexible graphite reinforced with flat, tanged, or corrugated metal insert; or (e) for use only in round bonnets, a filled spiral-wound metal. A filled spiral-wound metal gasket is acceptable, provided the gasket incorporates a centering/compression ring or the bonnet-to-body joint design provides inherent compression control to ensure the proper seating of the gasket. The gasket filler material shall be suitable for the conditions specified in 3.3.3.

3.3.2 The metallic portion of the gasket exposed to the service environment shall be made of a material that has corrosion resistance at least equal to that of the shell.

3.3.3 Unless otherwise specified in the purchase order, the gasket shall be suitable for the pressure rating of the valve within a valve design temperature range from -20°F (-29°C) to 1000°F (538°C).

3.3.4 A light lubricant, not heavier than kerosene, may be used to facilitate the makeup of metal gasketed joints, but the use of a sealing compound or grease is prohibited.

3.4 Gate

A gate on which seating surfaces are weld deposited shall be made of a material with corrosion resistance that is at least equal to that of the material of the shell.

3.5 Yoke

A yoke that is separate from the bonnet shall be made of carbon steel or of the same material as the shell.

3.6 Handwheel, Chainwheel, and Nut

3.6.1 Handwheels and chainwheels shall be made of carbon steel, ductile iron, or malleable iron. Unless otherwise specified in the purchase order, they shall be cast, forged, or fabricated from other carbon steel products, provided the strength and toughness are comparable to that of handwheels and chainwheels made by casting or forging. All handwheels shall be free from burrs and sharp edges.

3.6.2 The handwheel or chainwheel nut shall be made of a nonferrous copper alloy, austenitic stainless steel, malleable iron, ductile iron, or carbon steel. Chains shall be made of steel.

3.7 Stem Nut

The stem nut shall be made of nonferrous copper alloy or austenitic ductile iron, ASTM A 439—Type D-2 or Type D-2C; shall have a suitable bearing quality; and shall have a minimum melting point of 1750°F (954°C).

3.8 Gland Flange and Gland

The gland flange shall be made of steel material. The gland proper shall be made of a material having corrosion resistance at least equal to that of the valve shell.

3.9 Trim

3.9.1 The trim is comprised of the following:

- a. Stem.
- b. Body seating surface.
- c. Gate seating surface.
- d. Bushing, or a deposited weld, for the backseat and stem hole guide.
- e. Small internal parts that normally contact the service fluid, excluding the pin that is used to make a stem-to-gate connection. (This pin shall be made of an austenitic stainless steel material.)

3.9.2 The trim material, except as stated in Items a through d below, shall be the manufacturer's standard material for the type listed in Table 3 for the trim number specified in the purchase order. The typical specifications included in Table 3 represent some acceptable grades.

- a. If a trim number listed in Table 4 is specified, then an alternative trim number as shown in Table 4 may be furnished.
- b. If a single trim (Trim Number 1, 2, 3, 4, 5, 5A, 9, 10, or 13) is furnished, both the seating surface of the body seat ring and the seating surface of the gate shall be made of the type of material shown in Table 3.
- c. If a combination trim (Trim Number 6, 7, 8, 8A, 11, 12, or 14) is furnished, the seating surface of the body seat ring shall be made of one of the two types of material shown in Table 3, and the seating surface of the gate shall be made of the other type of material shown.
- d. The stem, the backseat and stem hole guide, and the small internal parts (see 3.9.1, Item e) shall be of the type of mate-

rial and hardness listed in Table 3. The stem shall be a wrought material.

3.10 Lantern Ring

If a lantern ring is furnished, it shall be made of a material whose corrosion resistance is at least equal to that of the shell material.

3.11 Stem Packing

Unless otherwise specified in the purchase order, the packing shall be suitable for steam and petroleum fluid for the pressure rating of the valve within the valve design temperature range from -20°F (-29°C) to 1000°F (538°C). The packing shall contain a corrosion inhibitor.

3.12 Bolting

3.12.1 The bonnet bolts shall be ASTM A 193, Grade B7, and the nuts shall be ASTM A 194, Grade 2H, unless another bolt material is specified in the purchase order for a temperature less than -20°F (-29°C) or greater than 850°F (454°C) or for increased resistance to corrosive environments.

3.12.2 The material used for the gland and yoke bolting shall be at least equal to ASTM A 307, Grade B.

3.13 Plug

The material used for pipe plugs for tapped connections shall have the same nominal chemical composition as the shell material.

3.14 Bypass

The material used for any bypass valve shell and its piping shall have the same nominal chemical composition as the shell material.

3.15 Nameplate

3.15.1 For valve sizes larger than or equal to NPS 6, the material of the nameplate shall be 18Cr-8Ni steel or nickel alloy. The nameplate shall be attached to the valve with pins made of a similar material or by welding.

3.15.2 For valve sizes less than or equal to NPS 4, the nameplate material and means of attachment shall be the manufacturer's standard, using a metal resistant to atmospheric corrosion. Nameplates made of brass or aluminum are acceptable.

Table 3—Nominal Seating Surface, Stem and Backseat Bushing or Weld-Deposit Materials and Hardness

Trim Number	Nominal Trim	Seat Surface			Stem/Bushing				
		Hardness (HB) minimum (a)	Material Type (b)	Typical Specification (Grade)		Material Type (b)	Typical Specifications Type	Stem Hardness (HB)	Backseat Bushing Hardness (HB)
				Cast	Forged				
1	F6	(c)	13Cr	ASTM A217 (CA15)	ASTM A182 (F6a)	AWS A5.9 ER410	13Cr	ASTM A276-T410 or T420	250 min.
2	304	(d)	18Cr-8Ni	ASTM A351 (CF8)	ASTM A182 (F304)	AWS A5.9 ER308	18Cr-8Ni	ASTM A276-T304	200 min., 275 max.
3	F310	(d)	25Cr-20Ni	•	ASTM A182 (F310)	AWS A5.9 ER310	25Cr-20Ni	ASTM A276-T310	(d)
4	Hard F6	750 (e)	Hard 13Cr	•	(f)	•	13Cr	ASTM A276-T410 or T420	250 min.
5	Hardfaced	350 (e)	Co-Cr-A (g)	•	•	AWS A5.13 E or R CoCrA	13Cr	ASTM A276-T410 or T420	200 min., 275 max.
5A	Hardfaced	350 (e)	Ni-Cr	•	(h)	(h)	13Cr	ASTM A276-T410 or T420	200 min., 275 max.
6	F6 and Cu-Ni	250 (f)	13Cr	ASTM A217 (CA15)	ASTM A182 (F6a)	AWS A5.9 ER410	13Cr	ASTM A276-T410 or T420	200 min., 275 max.
		175 (f)	Cu-Ni	•	(k)	•	•	•	•
7	F6 and Hard F6	250 (f)	13Cr	ASTM A217 (CA15)	ASTM A182 (F6a)	AWS A5.9 ER410	13Cr	ASTM A276-T410 or T420	200 min., 275 max.
		750 (f)	Hard 13Cr	•	(f)	•	•	•	•
8	F6 and Hardfaced	250 (f)	13Cr	ASTM A217 (CA15)	ASTM A182 (F6a)	AWS A5.9 ER410	13Cr	ASTM A276-T410 or T420	200 min., 275 max.
		350 (f)	Co-Cr-A (g)	•	•	AWS A5.13 E or R CoCrA	•	•	•
8A	F6 and Hardfaced	250 (f)	13Cr	ASTM A217 (CA15)	ASTM A182 (F6a)	AWS A5.9 ER410	13Cr	ASTM A276-T410 or T420	200 min., 275 max.
		350 (f)	Ni-Cr	•	(h)	(h)	•	•	•
9	Monel	(d)	Ni-Cu alloy	•	MFG. Standard	•	Ni-Cu alloy	MFG. Standard	(d)
10	316	(d)	18Cr-8Ni	ASTM A351 (CF8M)	ASTM A182 (F316)	AWS A5.9 ER316	18Cr-8Ni	ASTM A276-T316	(d)
11	Monel and Hardfaced	(d)	Ni-Cu alloy	•	MFG. Standard	•	Ni-Cu alloy	MFG. Standard	(d)
		350 (f)	Trim 5 or 5A	•	•	See Trim 5 or 5A	•	•	(d)
12	316 and Hardfaced	(d)	18Cr-8Ni	ASTM A351 (CF8M)	ASTM A182 (F316)	AWS A5.9 ER316	18Cr-8Ni	ASTM A276-T316	(d)
		350 (f)	Trim 5 or 5A	•	•	See Trim 5 or 5A	•	•	(d)
13	Alloy 20	(d)	19Cr-29Ni	ASTM A351 (CN7M)	ASTM B473	AWS A5.9 ER320	19Cr-29Ni	ASTM B473	(d)
14	Alloy 20 and Hardfaced	(d)	19Cr-29Ni	ASTM A351 (CN7M)	ASTM B473	AWS A5.9 ER320	19Cr-29Ni	ASTM B473	(d)
		350 (f)	Trim 5 or 5A	•	•	See Trim 5 or 5A	•	•	(d)
15	Hardware	350 (e)	Co-Cr-A (g)	•	•	AWS A5.13 E or R CoCrA	18Cr-8Ni	ASTM A276-T304	(n)
16	Hardfaced	350 (e)	Co-Cr-A (g)	•	•	AWS A5.13 E or R CoCrA	18Cr-8Ni	ASTM A276-T316	(n)
17	Hardware	350 (e)	Co-Cr-A (g)	•	•	AWS A5.13 E or R CoCrA	18Cr-10Ni	ASTM A276-T347	(n)
18	Hardfaced	350 (e)	Co-Cr-A (g)	•	•	AWS A5.13 E or R CoCrA	19Cr-29Ni	ASTM B473	(n)

Note: Cr = Chromium; Ni = nickel; Co = cobalt; Cu = copper; * = Not applicable; (a) = HB (formerly BHN) is the symbol for the Brinell hardness per ASTM E 10; (b) = Free-machining grades of 13Cr are prohibited; (c) = Body and gate seat surfaces should be 250 HB minimum with a 50 HB minimum differential between the body and gate seat surfaces; (d) = Manufacturer's standard hardness; (e) = Differential hardness between the body and gate seat surfaces is not required; (f) = Case hardened by nitriding to a thickness of 0.13 millimeters (0.005 inch) minimum; (g) = This classification includes such trademarked materials as Stellite 6(TM), Stooey 6(TM), and Wallex 6(TM); (h) = Manufacturer's standard hardfacing with a maximum iron content of 25 percent; (i) = Hardness differential between the body and gate seat surfaces shall be the manufacturer's standard; (j) = Not used; (k) = Manufacturer's standard with 30 Ni minimum; (l) = Not used; (m) = Typical backseat weld deposit material; (n) = Per manufacturer's standard if not hardfaced; 250 HB minimum if hardfaced.

Table 4—Trim Numbers and Alternative Trim Numbers

Specified Trim Number	Alternative Trim Number
1	8 or 8A
2	10
5A	5
6	8
8A	8

SECTION 4—EXAMINATION, INSPECTION, AND TESTING

4.1 Inspection

If inspection by the purchaser is specified in the purchase order, inspection shall be in accordance with API Standard 598. Examination by the manufacturer shall be as specified in API Standard 598.

4.2 Pressure Tests

Each valve shall be pressure tested as specified in API Standard 598.

4.3 Repair of Defects

Defects in the shell of a cast or forged, carbon or alloy steel valve that are revealed by inspection or testing may be repaired as permitted by the most nearly applicable ASTM cast or forged material specification listed in ASME B16.34.

SECTION 5—MARKING

Valves shall be marked in accordance with the requirements of ASME B16.34, except that the nameplate may

include the designation "API 600" in addition to the designation ASME B16.34.

SECTION 6—SHIPMENT

6.1 Coatings

6.1.1 Unmachined exterior surfaces of the shell shall be painted per the manufacturer's standard paint with an aluminum or silver color. Austenitic stainless steel valves shall not be painted.

6.1.2 Machined or threaded surfaces (except those on austenitic stainless steel materials) shall be coated with an easily removable rust preventive. The stem does not need to be coated if the stem packing contains a sacrificial metal corrosion inhibitor.

6.2 Openings

6.2.1 Valve end flanges and welding ends shall be blanked to protect the gasket surfaces or welding ends and the valve internals during shipment and storage. The protective covers shall be made of wood, wood fiber, plastic, or metal and shall be securely attached to the valve ends by bolts, steel straps, steel clips, or suitable friction-locking devices. Covers shall be designed so that the valve cannot be installed without removal of the protective cover.

6.2.2 Tapped connections shall be fitted with fully tightened threaded plugs (see 2.1.10 and 3.13).

6.3 Gate Position

The valve shall be shipped with the gate closed.

6.4 Stem Packing

The valve shall be shipped with the lantern ring, if specified, and the packing installed. The remaining adjustment length of the packing gland at the time of shipment, with the gland tight, shall be greater than one-and-one-half times the packing width specified in Table 2.

6.5 Packaging

6.5.1 Unless export packaging is specified in the purchase order, valves may be shipped loose, palletized, or packed in a box or crate.

6.5.2 When export packaging is specified in the purchase order, valves shall be shipped individually or collectively in wooden boxes or crates in a manner that will prevent shifting within the package.

APPENDIX A—REQUIREMENTS FOR PRESSURE SEAL GATE VALVES

This appendix contains the requirements for pressure seal bonnet gate valves. The organization, content, and paragraph designations correspond to those in the main body of this

standard. Provisions and requirements of the main body of this standard apply to pressure seal bonnet gate valves except as modified in this appendix.

SECTION A.1—GENERAL

A.1.1.1 This appendix covers pressure seal bonnet steel gate valves with flanged or butt-welding ends in NPS 2 through 24. These sizes correspond to nominal pipe sizes in ASME B36.10M.

A.1.1.2 This appendix covers valves in Classes 600 through 2500 as specified in ASME B16.34.

A.1.1.3 This appendix covers two styles of pressure seal bonnet valves with outside screw-and-yoke (OS&Y), rising stems, nonrising handwheels, and various types of gates. The two styles of pressure seal bonnet valves are as follows:

a. Style A valves are in accordance with ASME B16.34 and other requirements in this appendix.

b. Style B valves are in accordance with API Standard 600 and this appendix.

It is the responsibility of the purchaser to specify the style of valve required for the intended application.

A.1.1.4 Figure A-1 illustrates a pressure seal bonnet gate valve for the purposes of identifying nomenclature used in this appendix for valve components.

A.1.3.1 ASME B16.34 Special Class butt-weld end valves may be furnished on agreement with the purchaser.

SECTION A.2—DESIGN

A.2.1.1 The thickness of the body wall of the Style A pressure seal bonnet steel gate valve shall conform to the requirements of ASME B16.34. The thickness of the body wall of the Style B pressure seal bonnet steel gate valves shall conform to the requirements of Tables 1A or 1B.

A.2.1.7 The inside diameter of the seat opening of Style A pressure seal bonnet valves shall not be less than 90 percent of that specified in Annex A of ASME B16.34 for the nominal pipe size and pressure class, unless otherwise agreed to by the purchaser. The nominal inside diameter of the seat opening of Style B pressure seal bonnet valves shall not be less than that specified in Annex A of ASME B16.34 for the nominal pipe size and pressure, unless otherwise agreed by the purchaser.

A.2.1.9 Body seat surfaces shall be of hardfaced material that is weld deposited on either separate seat rings welded into the body or directly onto the body. The minimum finished thickness of the hardfacing material shall be 0.06 inch (1.6 millimeters). Seating surfaces shall be finished with a chamfer or radius on the outside and inside diameters.

A.2.2.1 For Style A valves, the minimum thickness of the bonnet wall shall conform to the requirements of ASME B16.34. For Style B valves, the minimum thickness of the bonnet wall shall conform to Tables 1A or 1B. These thicknesses do not apply to the bonnet neck above the backseat.

A.2.2.2 The pressure seal body-to-bonnet joint shall be constructed such that the effective sealing force shall increase as internal pressure increases.

A.2.2.5 The bonnet backseat shall be a bushing welded at the stem hole or an integral weld deposit. The seating surface shall be a hardfaced material in accordance with Table 5. Weld deposited backseat facings shall have a minimum finished thickness of 0.06 inch (1.6 millimeters).

A.2.3.2 For Style B valves, a double-disc gate is not permitted unless specified by the purchaser.

A.2.3.3 If a wedge gate is used, a flexible wedge shall be furnished in sizes NPS 6 and larger, unless otherwise specified in the purchase order.

A.2.3.7 The gate and the shell shall have guide surfaces to minimize wear of the seats during normal operation of the valves and to ensure the alignment of the disc and stem in all orientations. The possible loss of metal due to corrosion, erosion, and abrasive wear or a combination of these factors shall be considered in the design of both the gate and the shell guide surfaces. In addition, the discs in a double disc seated valve may be in contact with the seats during the full travel of the gate.

A.2.3.8 Gate seating surfaces shall be weld deposited hardfacing material having a minimum finished thickness of 0.06 inch (1.6 millimeter).

A.2.6.1 For Style A valves, the minimum stem diameters shall be in accordance with Tables A-6A or A-6B. For Style B valves, the minimum stem diameters shall be in accordance with Tables 1A or 1B. The tabulated minimum stem diameters are not to be assumed to be the required stem diameters

Table A-6A—Style A Minimum Stem Diameter (Inches)

NPS	Pressure Class			
	600	900	1500	2500
2	0.75	0.75	0.75	0.75
3	0.75	0.75	0.87	0.87
4	0.75	0.87	1.00	1.12
6	1.00	1.25	1.37	1.50
8	1.25	1.37	1.75	1.75
10	1.50	1.75	2.13	2.25
12	1.75	2.00	2.25	2.50
14	2.00	2.25	2.50	—
16	2.25	2.50	2.75	—
18	2.50	2.50	—	—
20	2.75	—	—	—
24	3.00	—	—	—

for the materials listed in Table 3. They are instead an inspection minimum stem diameter. Strength levels of the listed stem materials can vary significantly. The determination of the required stem diameter, taking into account the valve application and the stem material strength characteristics, is the responsibility of the valve manufacturer.

A.2.7.1 Table 2 is not a requirement for Style A valves.

Table A-6B—Style A Minimum Stem Diameter (Millimeters)

NPS	Pressure Class			
	600	900	1500	2500
2	19.1	19.1	19.1	19.1
3	19.1	19.1	22.1	22.1
4	19.1	22.1	25.4	28.4
6	25.4	31.8	34.8	38.1
8	31.8	34.8	44.5	44.5
10	38.1	44.5	54.1	57.2
12	44.5	50.8	57.2	63.5
14	50.8	57.2	63.5	—
16	57.2	63.5	69.9	—
18	63.5	63.5	—	—
20	69.9	—	—	—
24	76.2	—	—	—

SECTION A.3—MATERIAL

A.3.3.1 The pressure seal gasket shall be the manufacturer's standard, but be limited to a ductile steel, austenitic stainless steel, or flexible graphite material with a corrosion inhibitor, unless otherwise specified in the purchase order.

A.3.3.5 Unless otherwise specified, Style B valves made of ASME B16.34 Group 1 materials shall have a series 300 stainless steel welded overlay on the body at the gasket sealing contact area.

A.3.3.6 The pressure seal bonnet retention/sealing combination shall be the manufacturer's standard based on a tested and proven design.

A.3.9.2 Valve trims shall be in accordance with A.2.1.9, A.2.2.5, A.2.3.8, and the stem material shall be in accordance with Table 3. Seating surfaces shall be a hardfaced material, per trim numbers 5, 15, 16, 17, and 18 in Table 3. Weld deposit facings shall have a minimum finished thickness of 0.06 inch (1.6 millimeters).

A.3.15 The material of the nameplate shall be 18Cr-8Ni steel or nickel alloy. The nameplate shall be attached to the valve with pins made of a similar material or by welding.

SECTION A.5—MARKING

A.5.1 Valves shall be marked in accordance with the requirements of ASME B16.34, except that the nameplate

may include the designation API 600A or API 600B, as applicable.

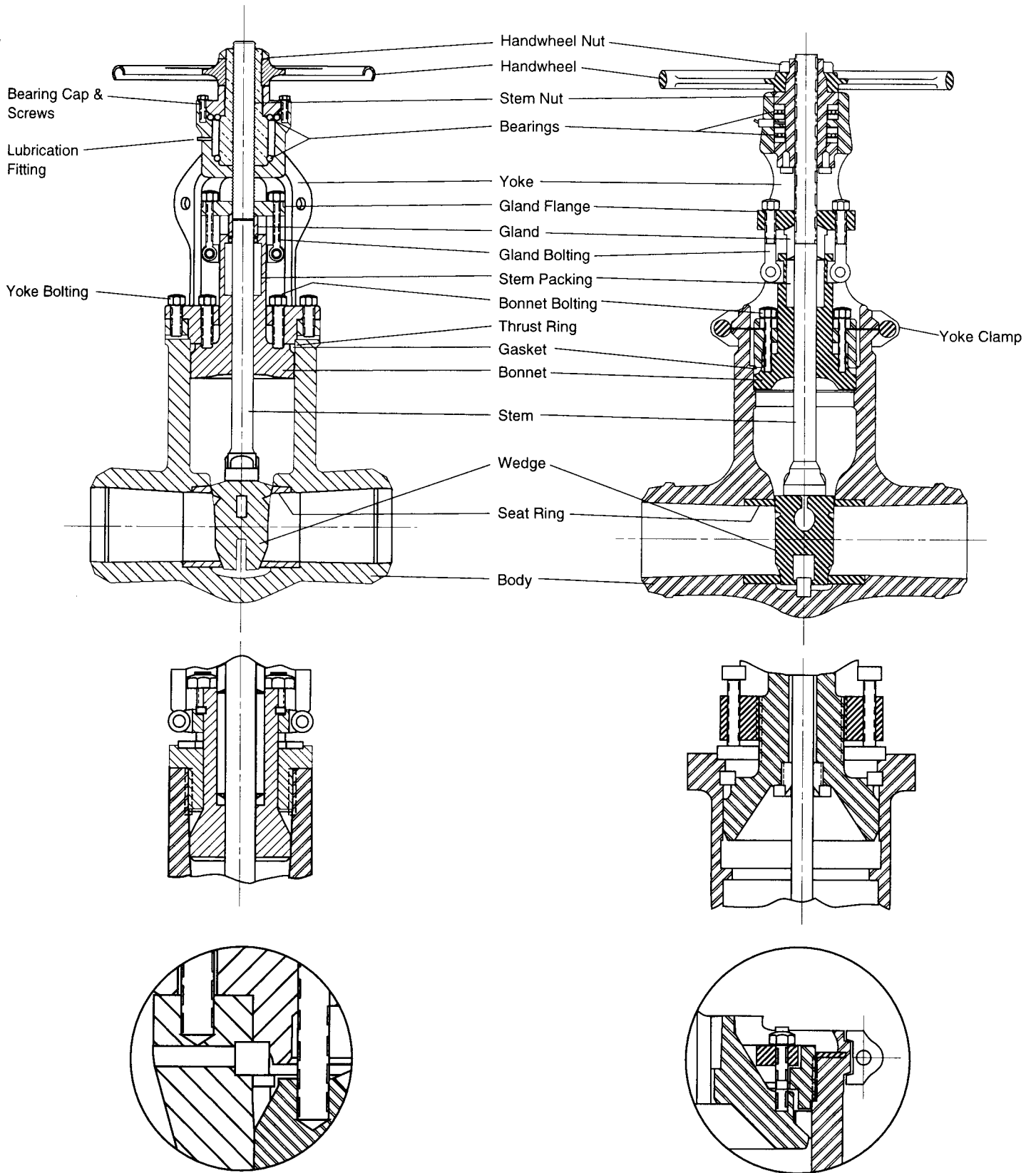

Note: See manufacturer's instruction manual for maintenance, operation, and service information

Figure A-1—Pressure Seal Bonnet Gate Valve Nomenclature

Additional copies available from API Publications and Distribution:
(202) 682-8375

Information about API Publications, Programs and Services is
available on the World Wide Web at: <http://www.api.org>

 **American
Petroleum
Institute** 1220 L Street, Northwest
Washington, D.C. 20005-4070
202-682-8000

Order No. C60010